

Lebanese Republic



Ministry of Energy and Water
Directorate of Water & Electrical Resources



WADI JEZZINE Potable Water Network

WADI JEZZINE Potable Water Network

List of Drawings:

Dwg: 1/2

Plan view 1/2000

Longitudinal Profile: Vertical: 1/200
Horizontal: 1/2000

Manholes Details

















Dwg: 2/2

Standard Details

Plan , Sections & Details
(Valve Chambers , House connections Type , Concrete
Reinforcement , Trench Section Details)

WADI JEZZINE Potable Water Network

Legend

	PROPOSED NEW LINE		75mm HDPE pipe
	SEWER MANHOLE		63mm HDPE pipe
	WATER MANHOLE		50mm HDPE pipe
	ELECTRIC MANHOLE		
	GULLY		
	SPOT SURVEY		
	SURVEY STAKE		
	MANHOLE		
	ROAD		
	BLDG		
	STAIRS		
	CANAL		
	SUMP LINE		
	Service Box		
	Valve Chamber		

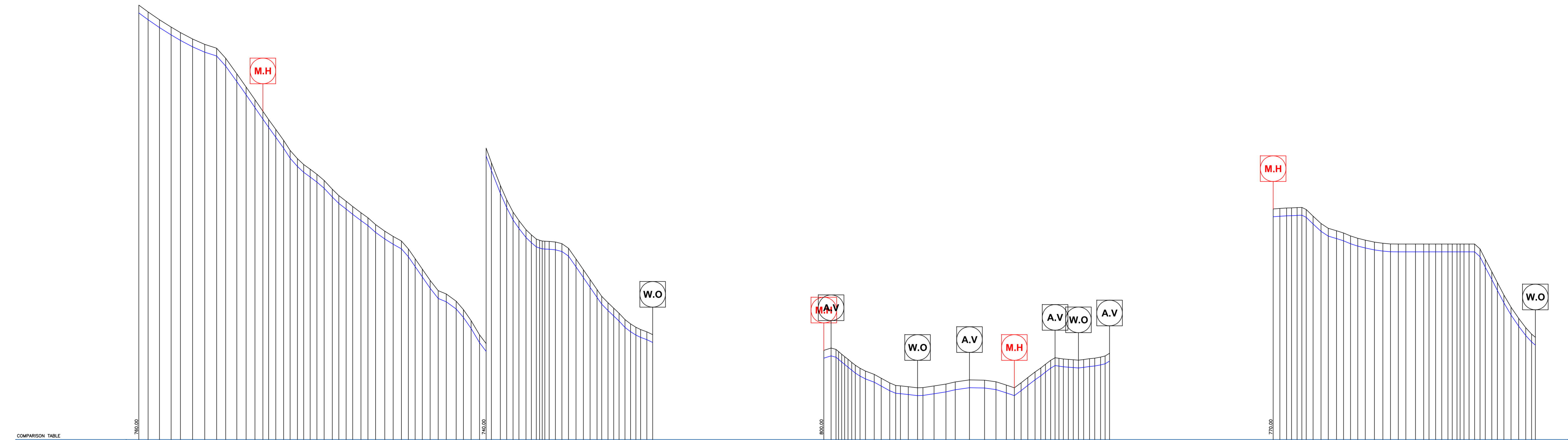
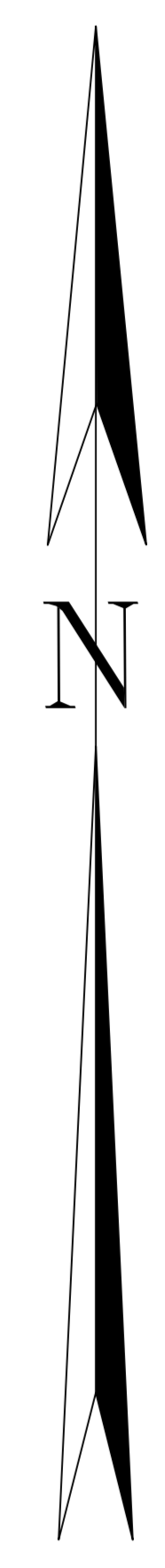
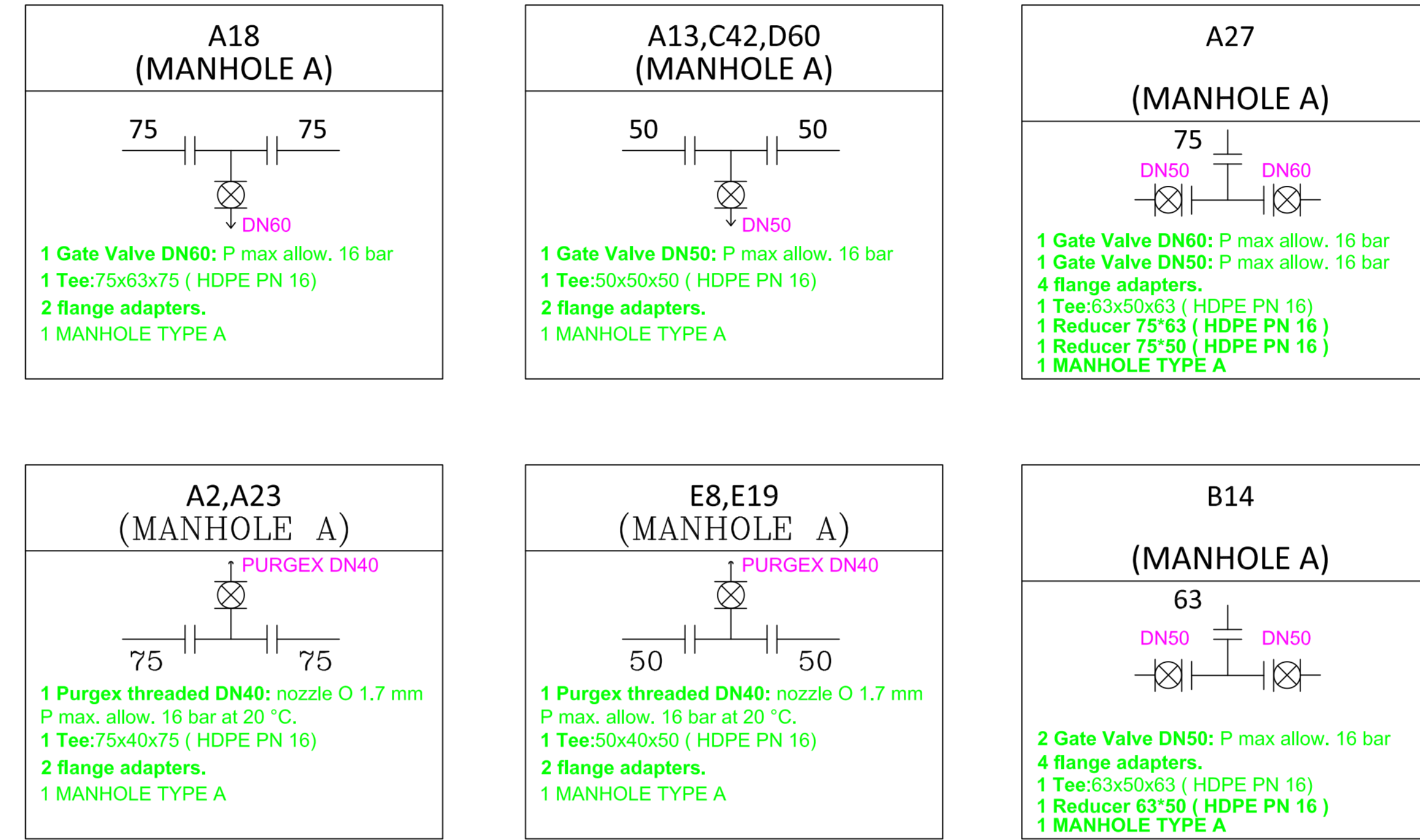
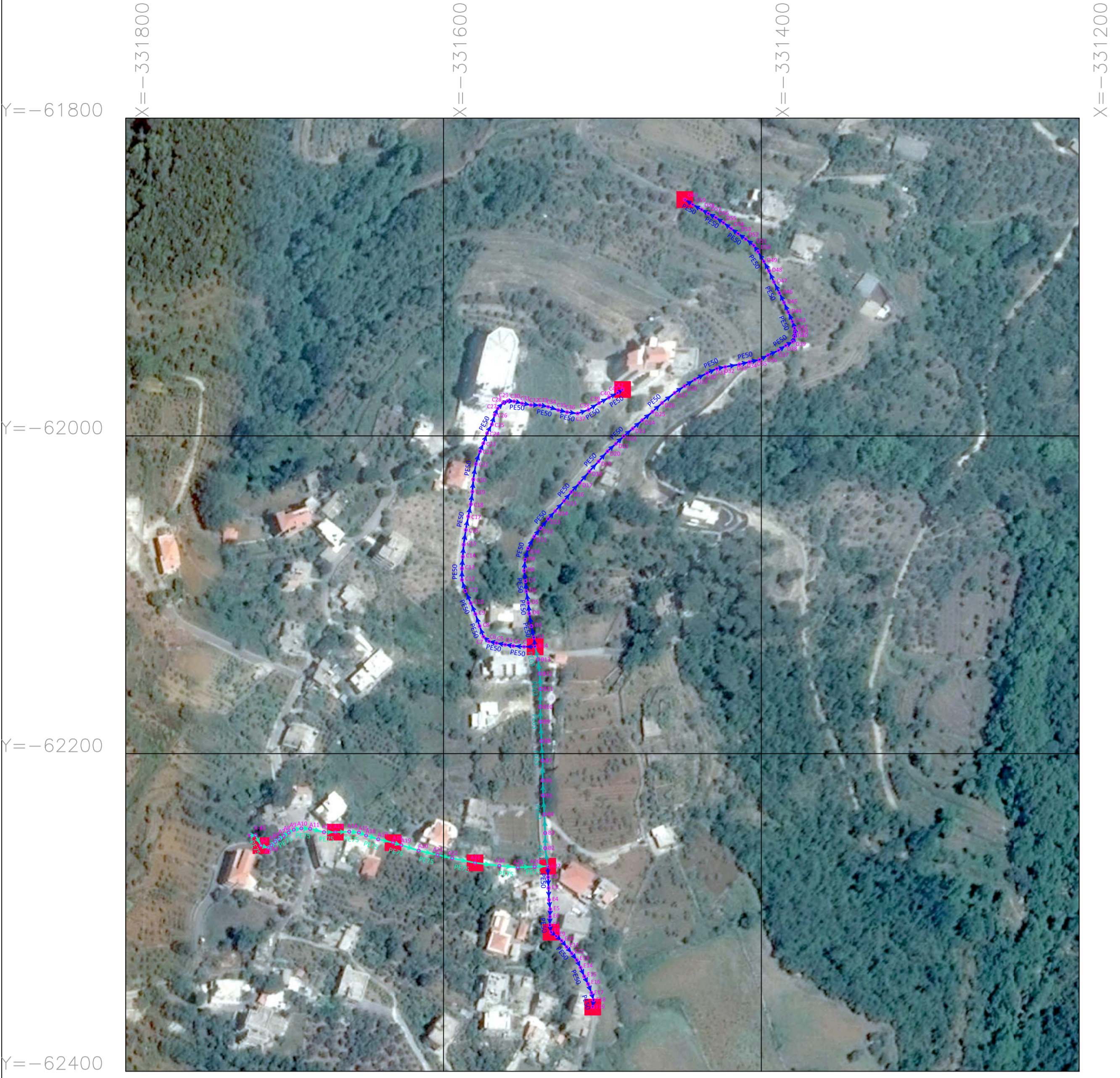

STATE - REFERENCE NUMBER	STATE - REFERENCE NUMBER	STATE - REFERENCE NUMBER
01	01	01
02	02	02
03	03	03
04	04	04
05	05	05
06	06	06
07	07	07
08	08	08
09	09	09
10	10	10
11	11	11
12	12	12
13	13	13
14	14	14
15	15	15
16	16	16
17	17	17
18	18	18
19	19	19
20	20	20
21	21	21
22	22	22
23	23	23
24	24	24
25	25	25
26	26	26
27	27	27
28	28	28
29	29	29
30	30	30
31	31	31
32	32	32
33	33	33
34	34	34
35	35	35
36	36	36
37	37	37
38	38	38
39	39	39
40	40	40
41	41	41
42	42	42
43	43	43
44	44	44
45	45	45
46	46	46
47	47	47
48	48	48
49	49	49
50	50	50
51	51	51
52	52	52
53	53	53
54	54	54
55	55	55
56	56	56
57	57	57
58	58	58
59	59	59
60	60	60
61	61	61
62	62	62
63	63	63
64	64	64
65	65	65
66	66	66
67	67	67
68	68	68
69	69	69
70	70	70
71	71	71
72	72	72
73	73	73
74	74	74
75	75	75
76	76	76
77	77	77
78	78	78
79	79	79
80	80	80
81	81	81
82	82	82
83	83	83
84	84	84
85	85	85
86	86	86
87	87	87
88	88	88
89	89	89
90	90	90
91	91	91
92	92	92
93	93	93
94	94	94
95	95	95
96	96	96
97	97	97
98	98	98
99	99	99
100	100	100

LEGEND

- 75mm HDPE pipe
- 63mm HDPE pipe
- 50mm HDPE pipe
- Service Box
- Valve Chamber

Lebanese Republic
Ministry of Energy and Water
Directorate of Water & Electrical Resources

WADI JEZZINE WATER PROJECT

PROJECT: Construction of New Potable Water Network in WADI JEZZINE Village-Caza JEZZINE	DATE: February 2017
DWG TITLE: Plan view - (1/1) Longitudinal Sections - (1/1) Manholes Details - (1/1)	Designed by: N.Z. Drawn by: D.G. Approved by: N.C. Checked by: N.C.
SCALE: Plan : 1/2000 Longitudinal Profile Vertical : 1/200 Horizontal : 1/2000	REMARKS: DRAWING SIZE A0
DWG N°:	REVISION:
Dwg: 1/2	DATE:



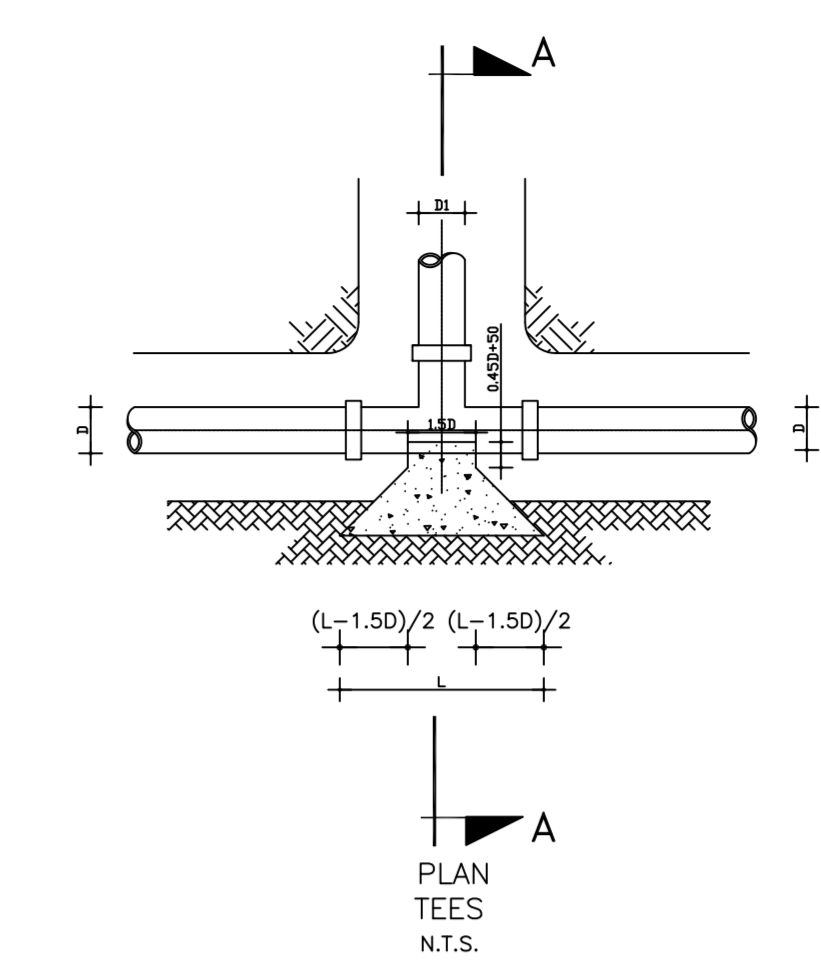
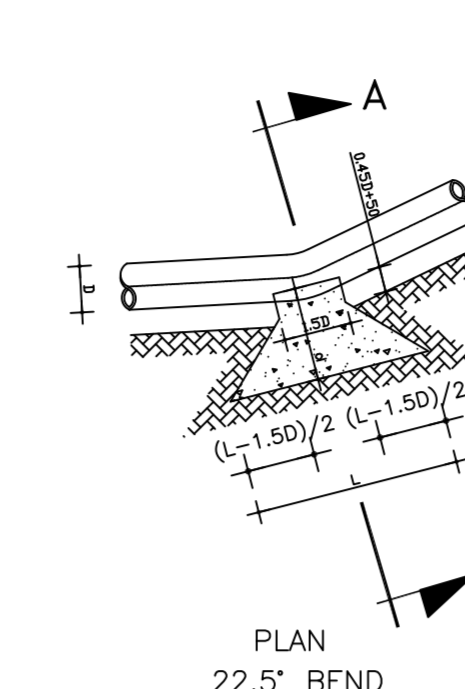
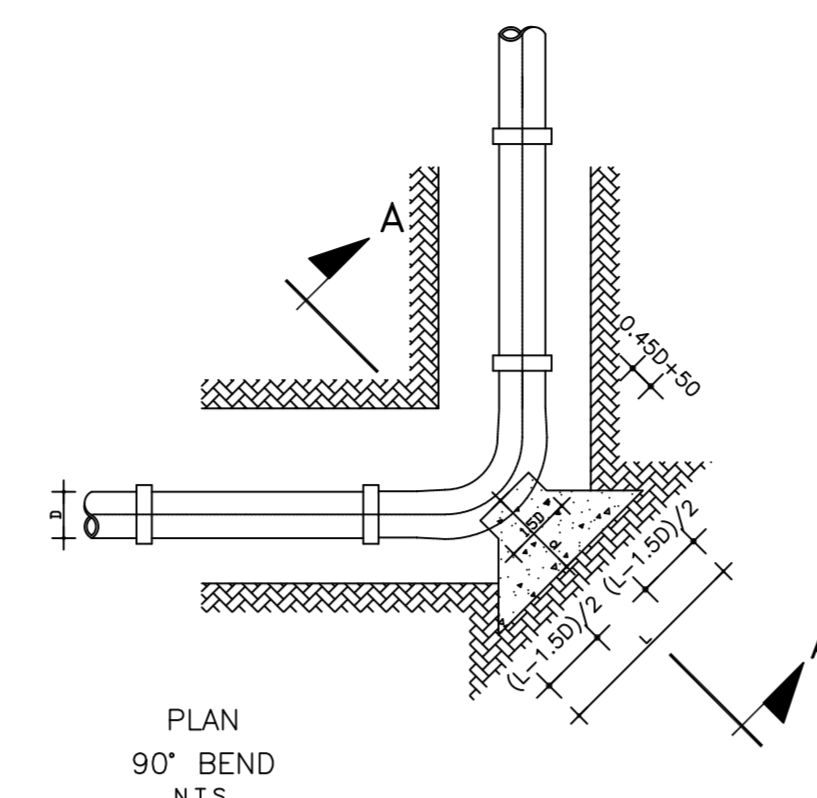
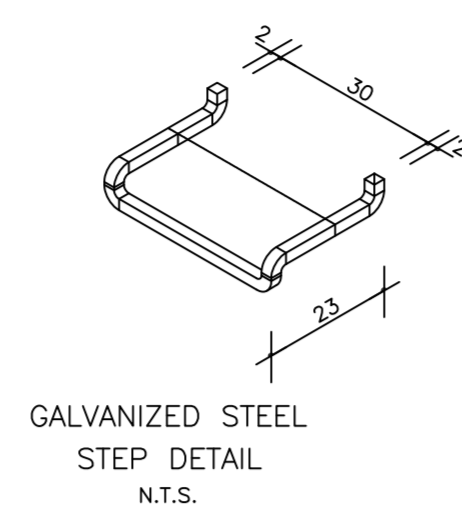
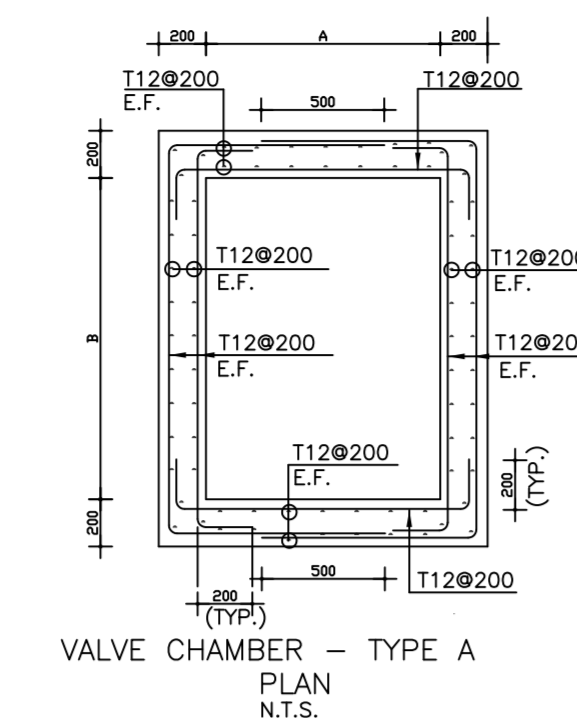
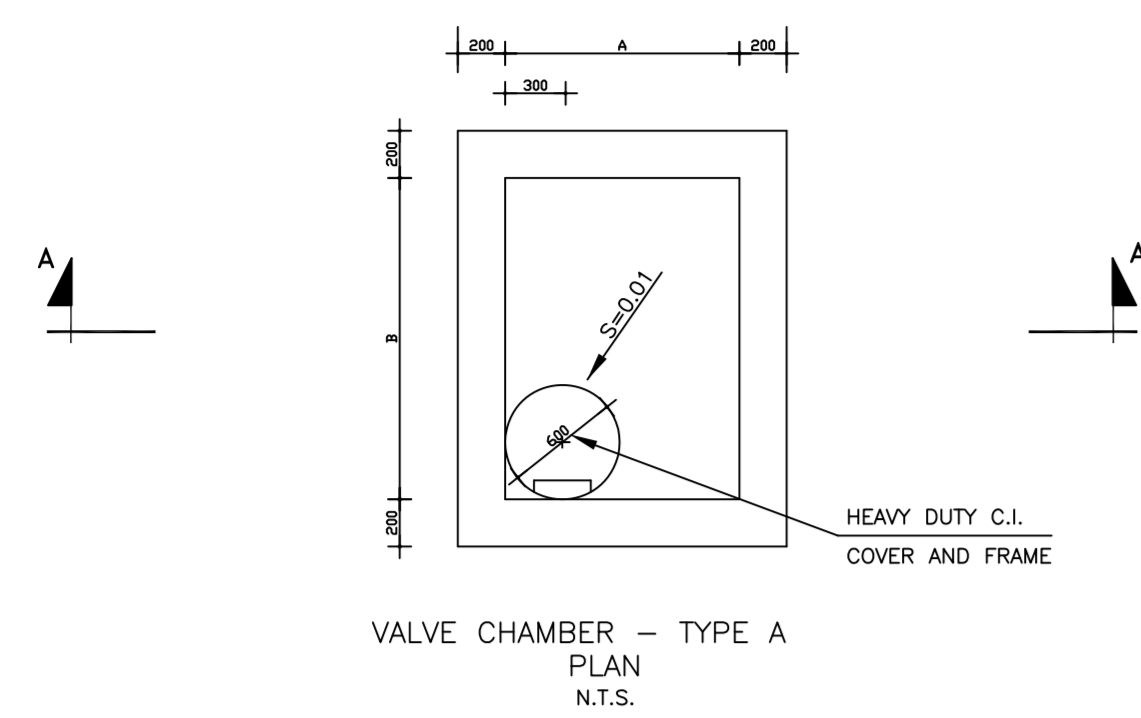

FOR BENDS 200 mm	H (mm)	L (mm)	d (mm)	v (m3)
11.25°	800	950	400	0.194
22.50°	800	1150	500	0.343
45°	800	1400	600	0.606
90°	800	1850	700	0.970
FOR TEES	800	1500	600	0.648

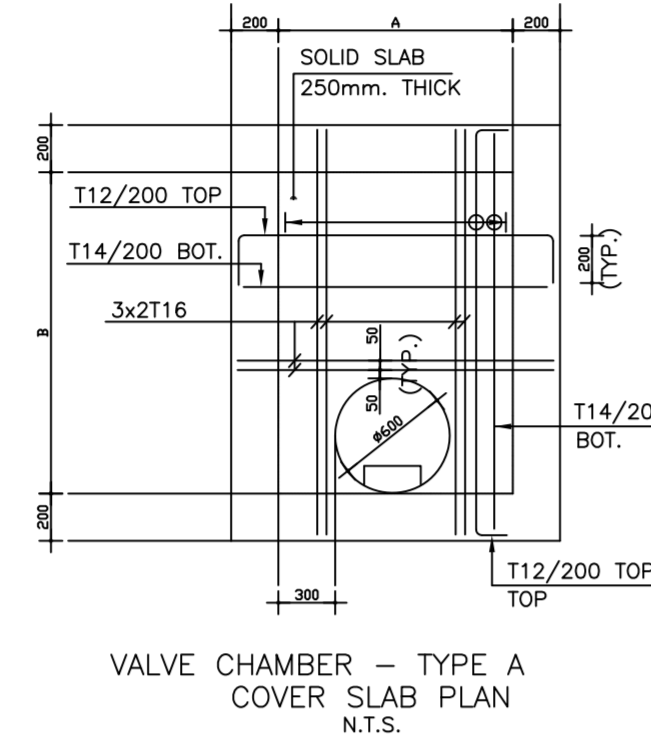
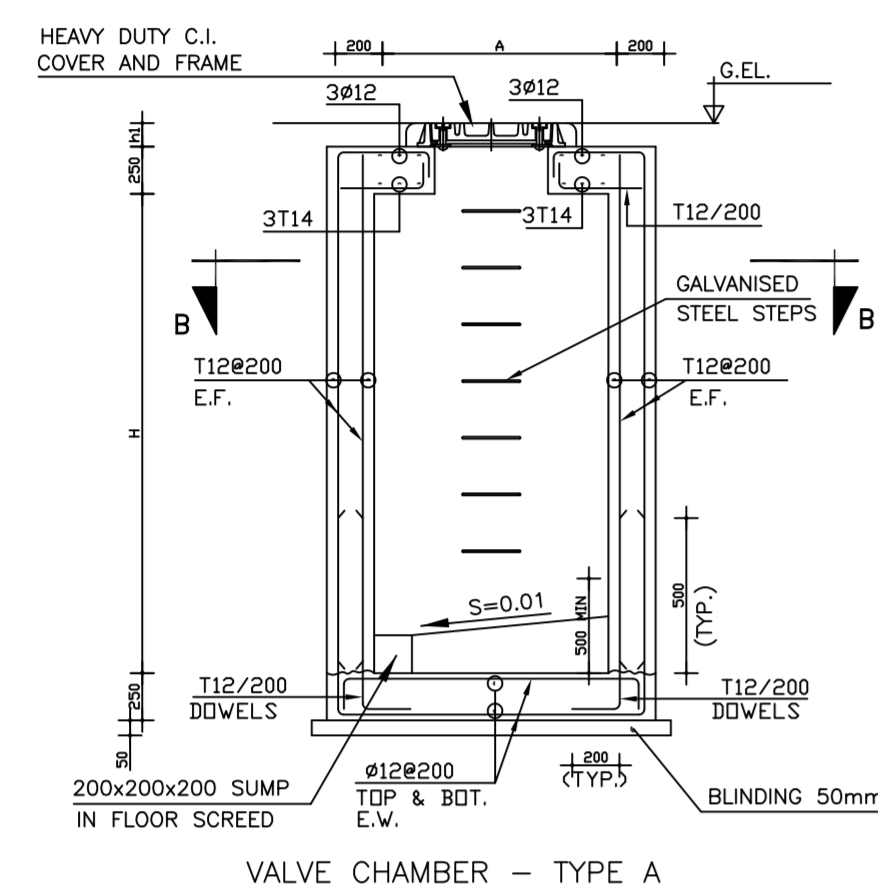

TYPE	DIMENSION A	DIMENSION B	Wall Thick (mm)	DIMENSION C (mm)	DIMENSION D (mm)
Type A	1000	1200	200	1500	2500
Type B	1200	1800	200	1500	2500
Type C	2000	2500	250	1500	2500

TABLE 1-VALVE CHAMBER DIMENSIONS

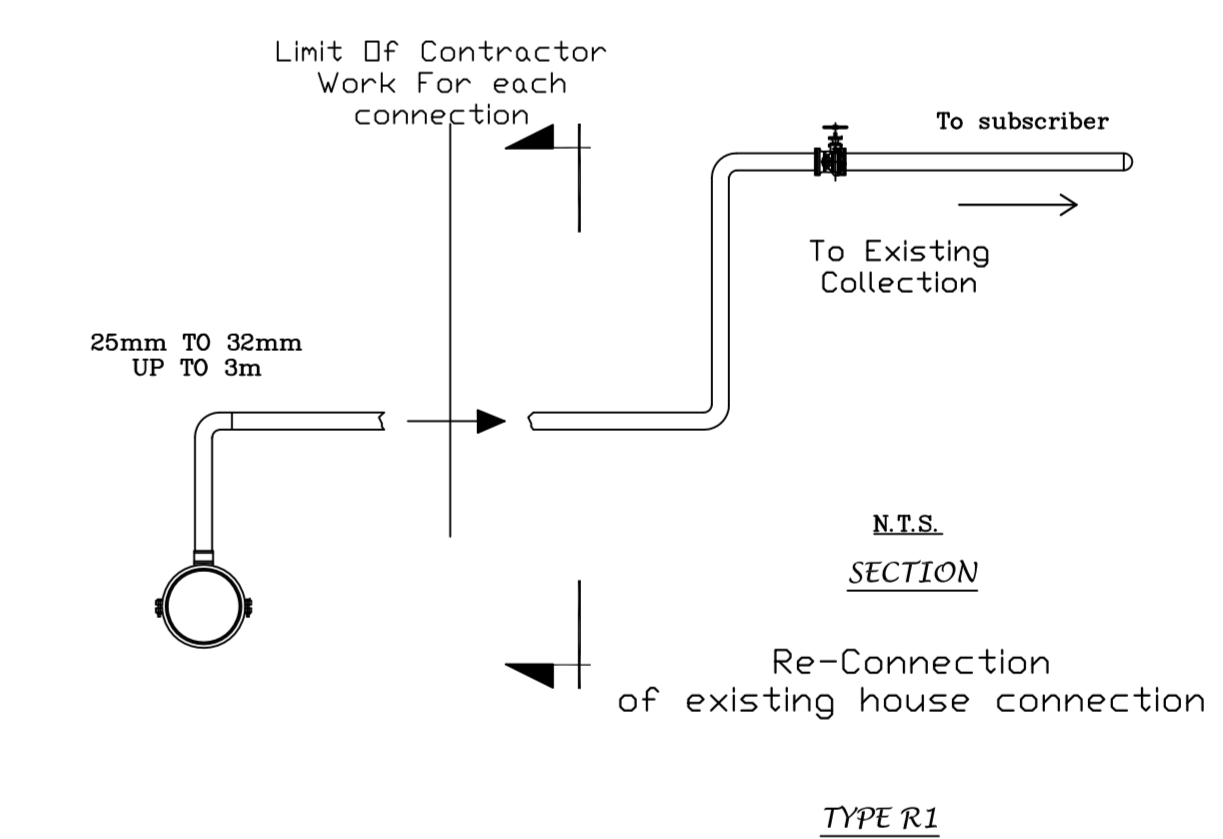
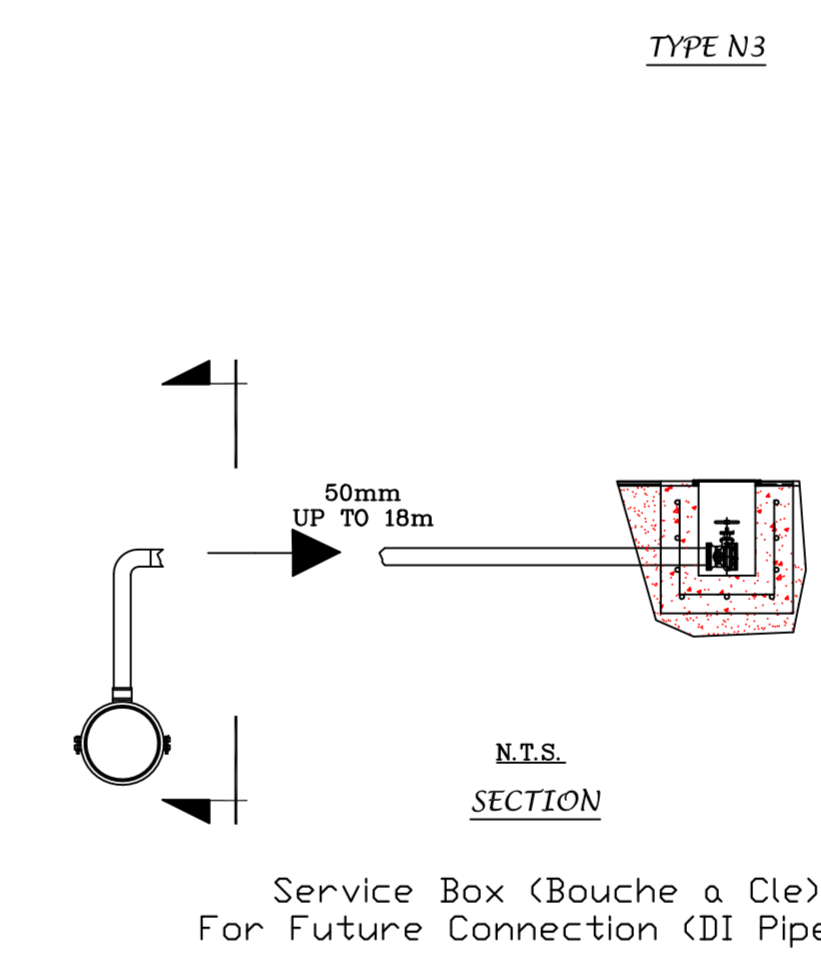
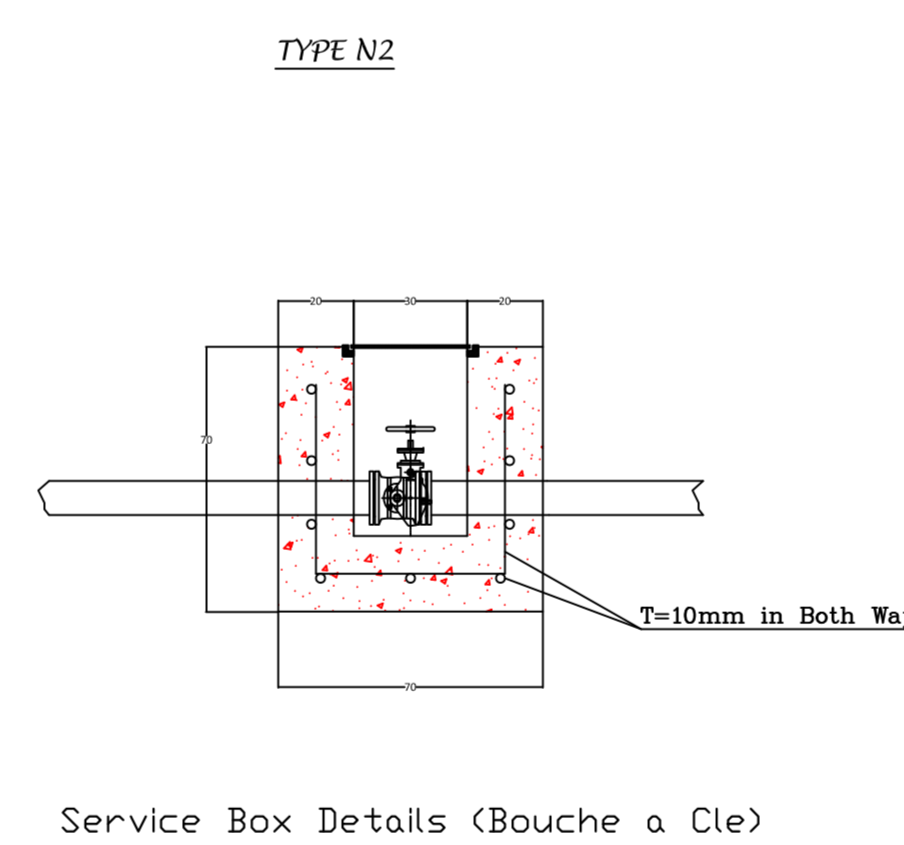
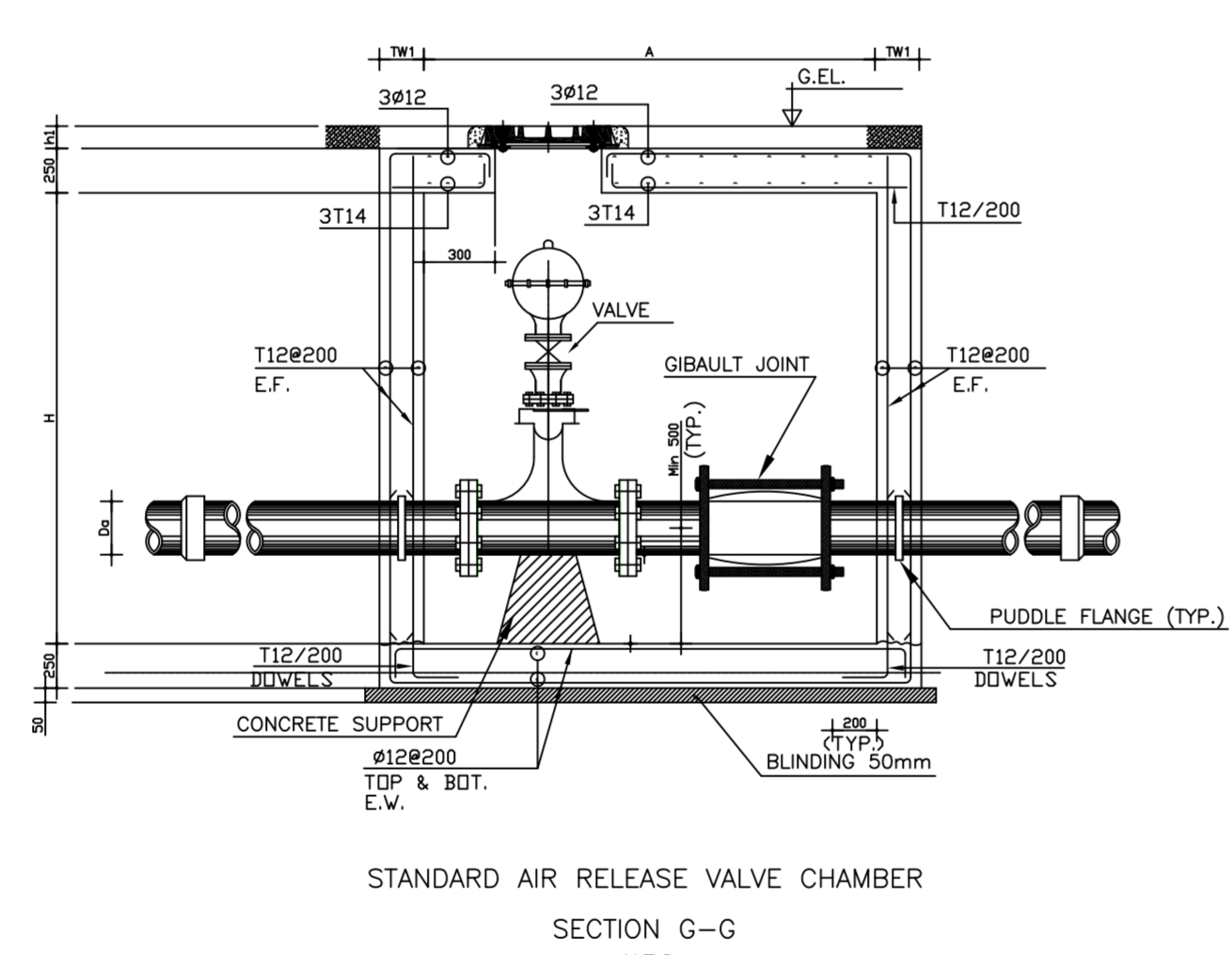
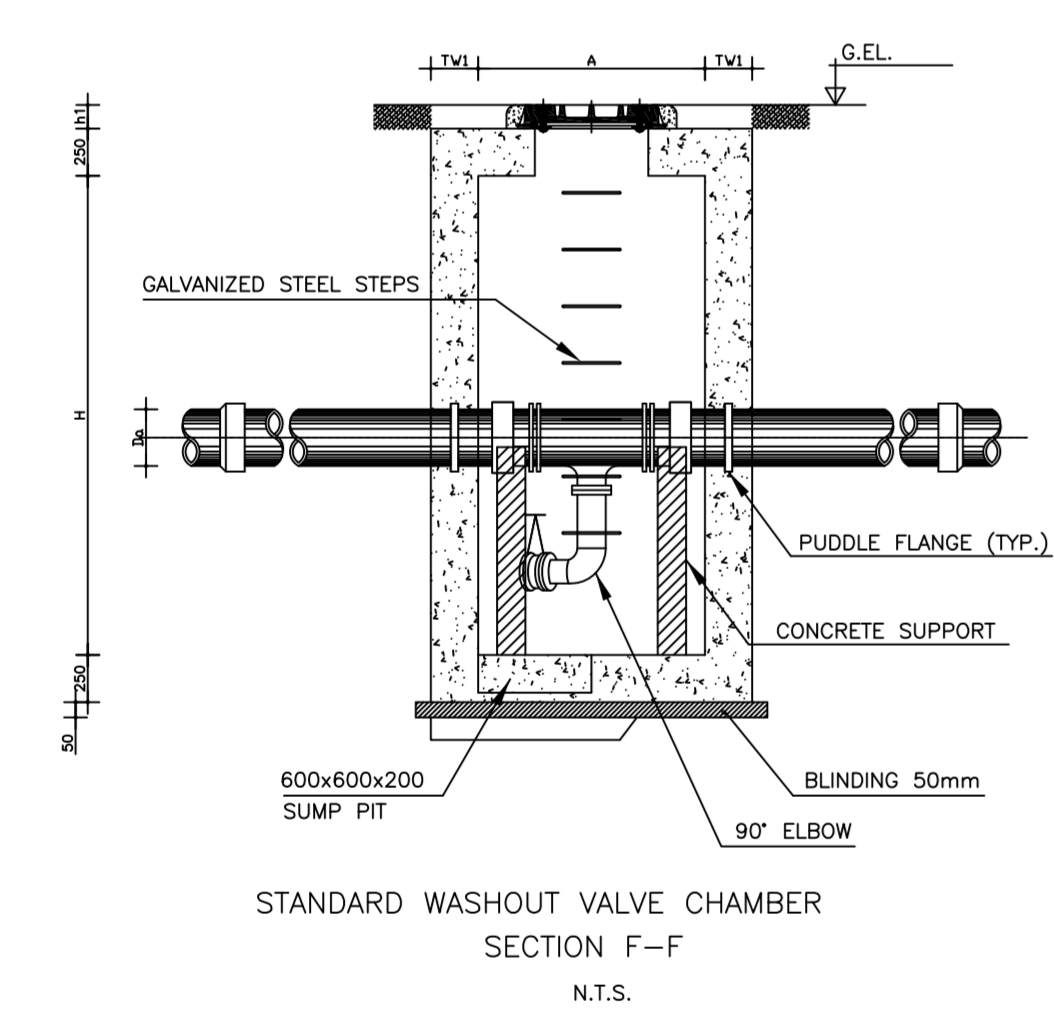
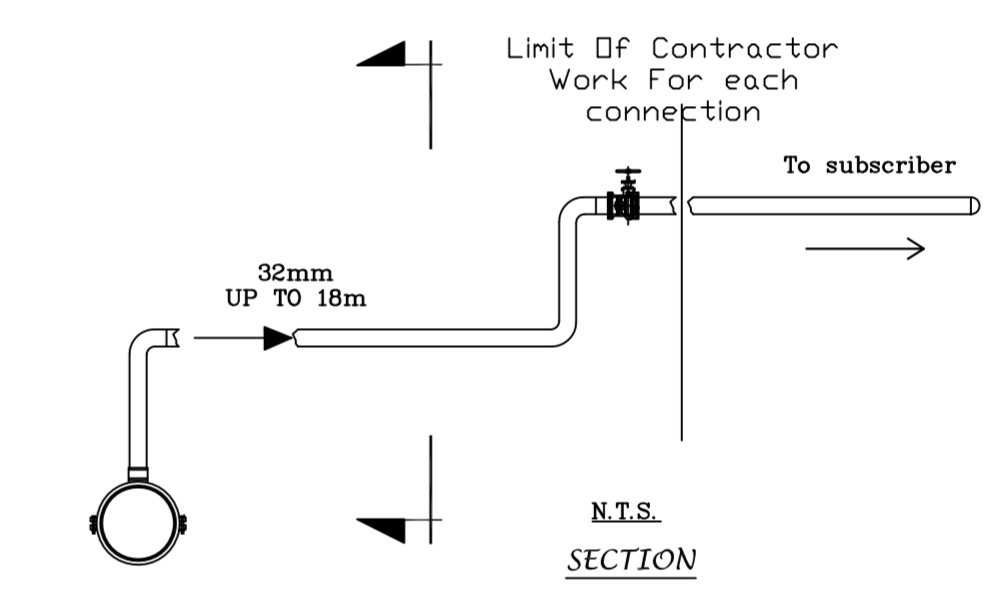
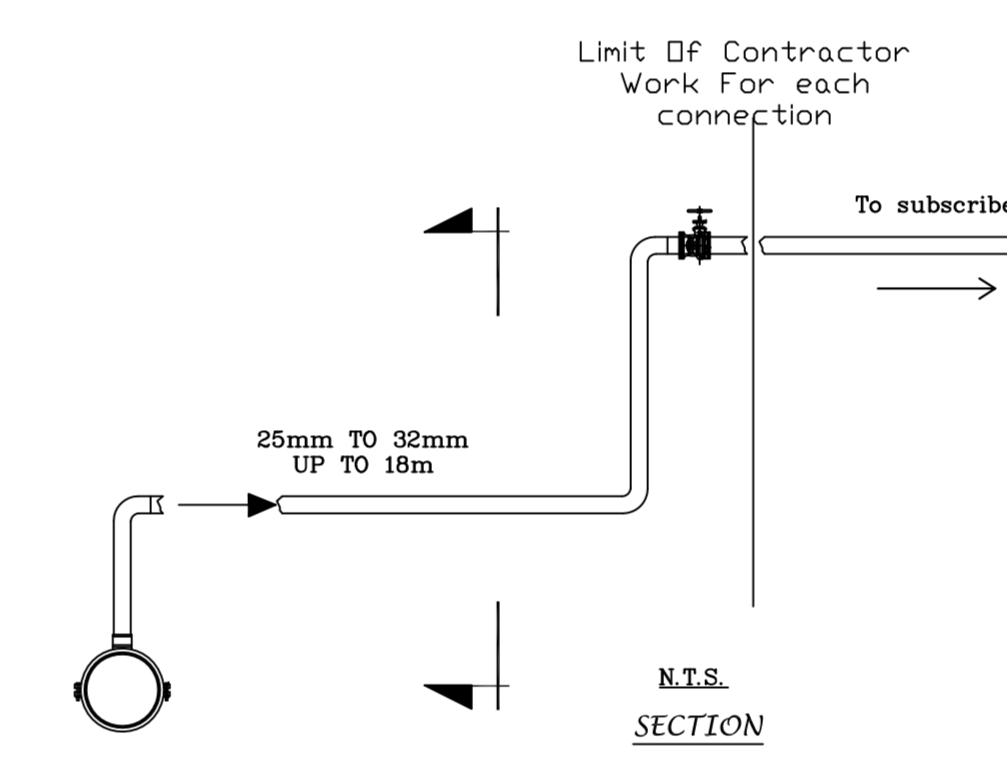
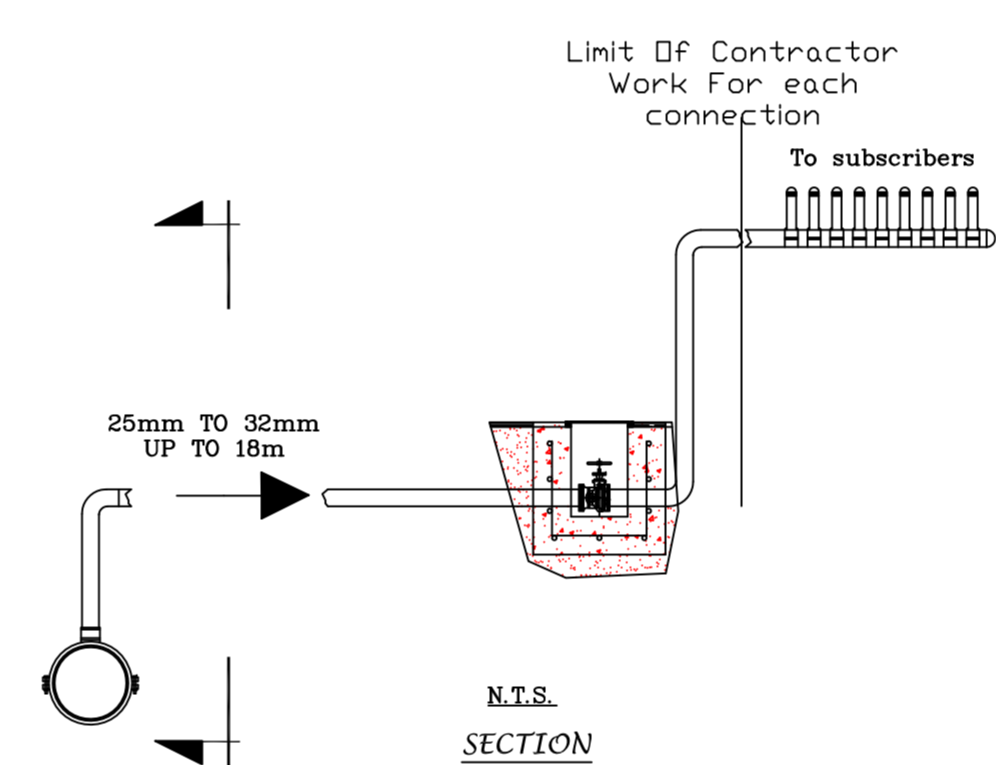
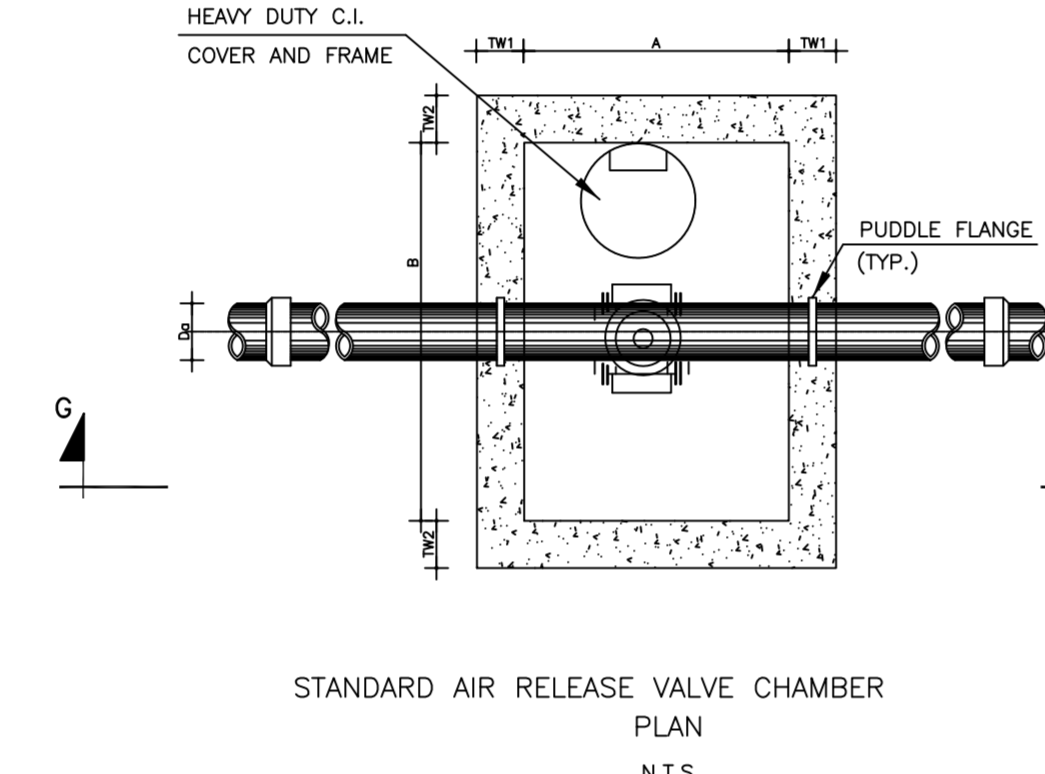
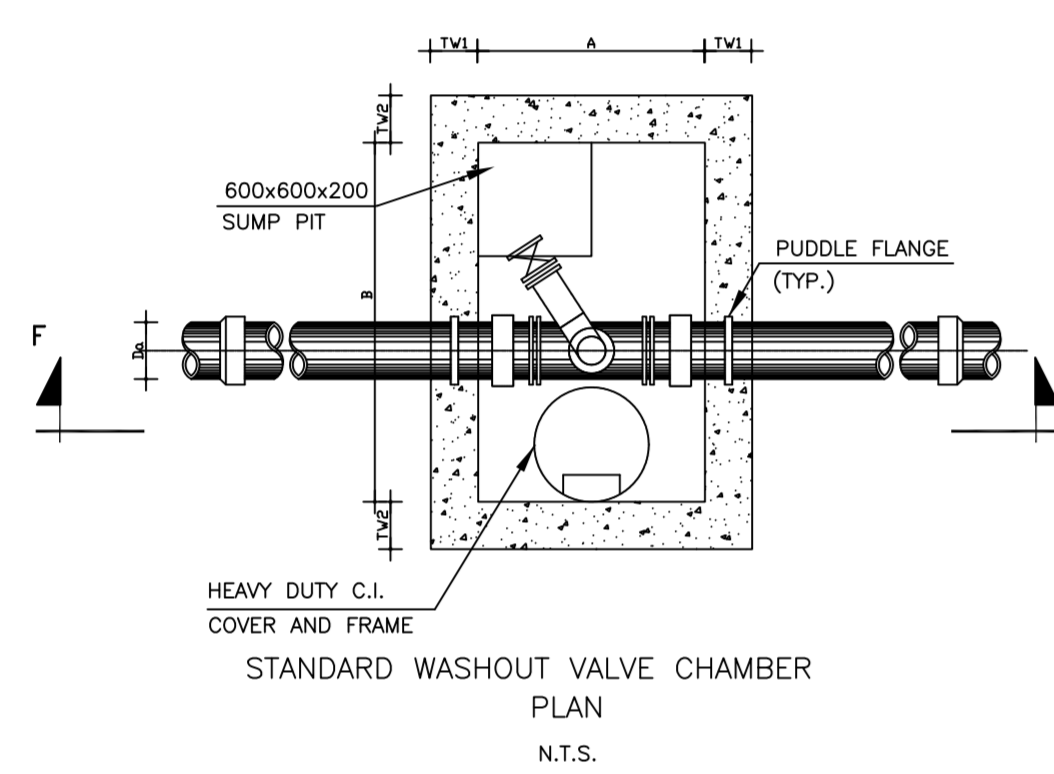
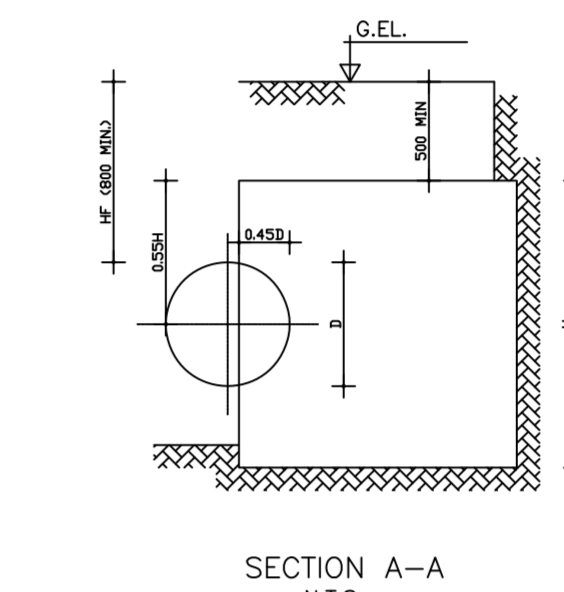
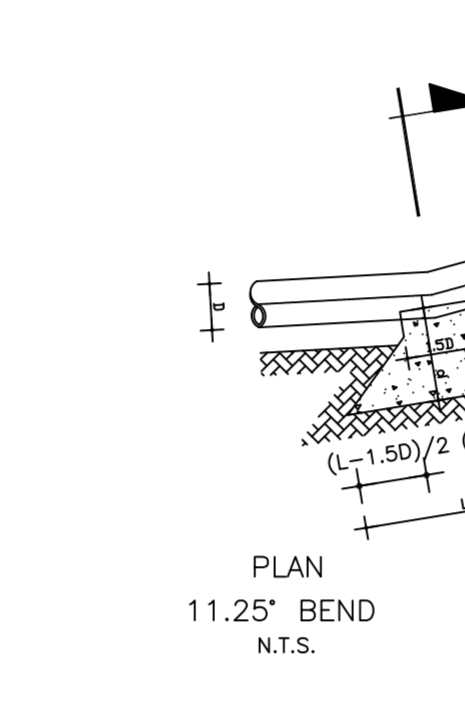
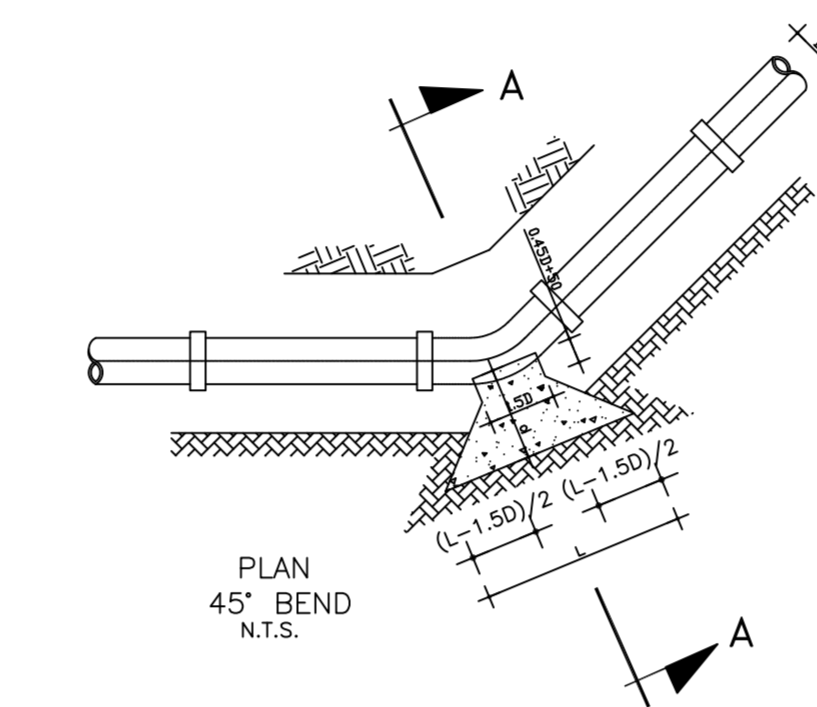

PIPE DIAMETER (mm)	MIN. TRENCH W (mm)	MIN. TRENCH H (mm)	TOTAL MIN. HEIGHT ABOVE PIPE (mm)
50	500	200	650
63 - 110	550	350	800
125 - 300	D + D + 450	400	850

BACKFILLING MATERIAL (SELECTED FINE CRUSHED ROCKS OR ORDINARY FILL)

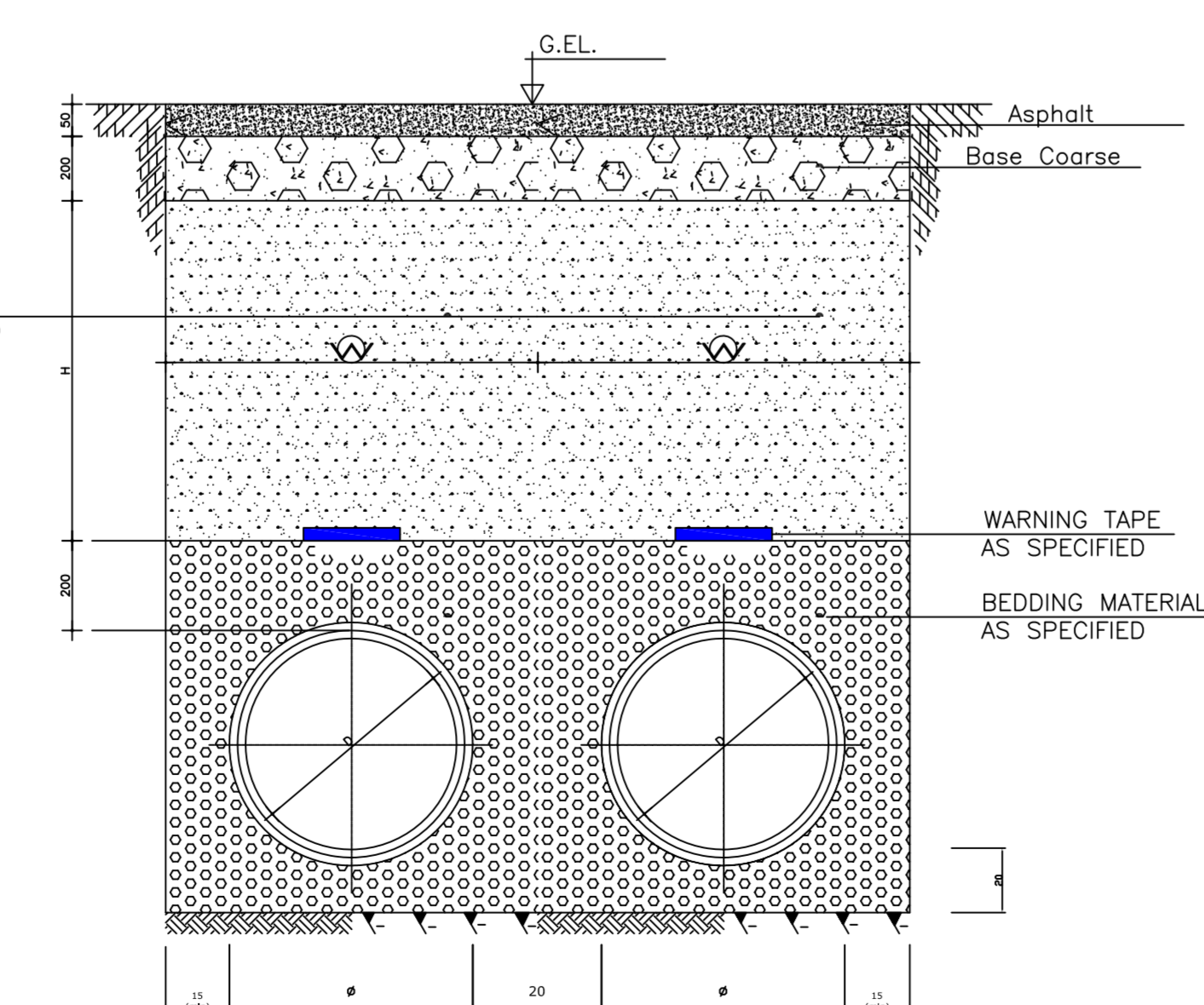

Typical Trench N.T.S.

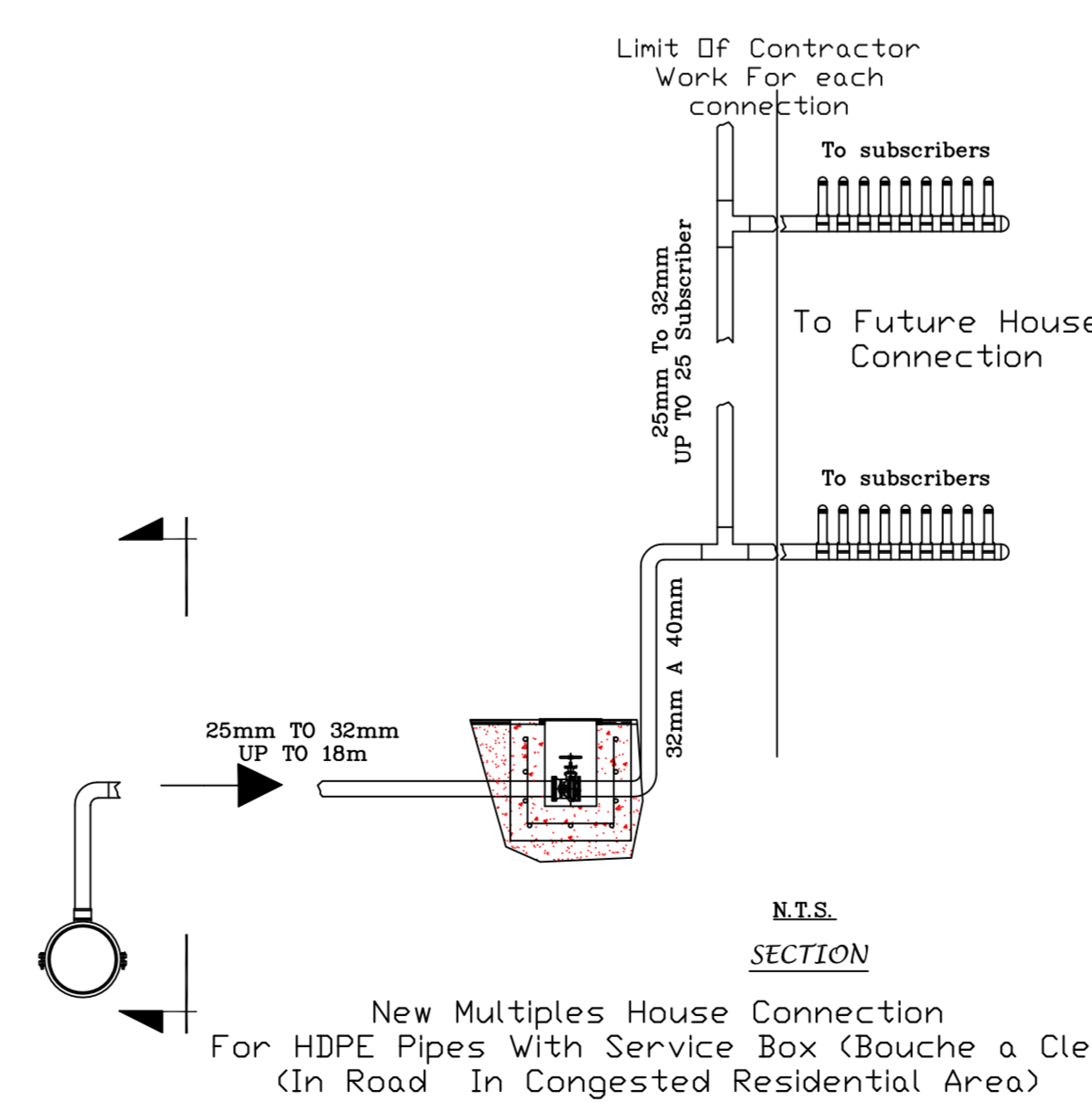

TYPE N3-E1

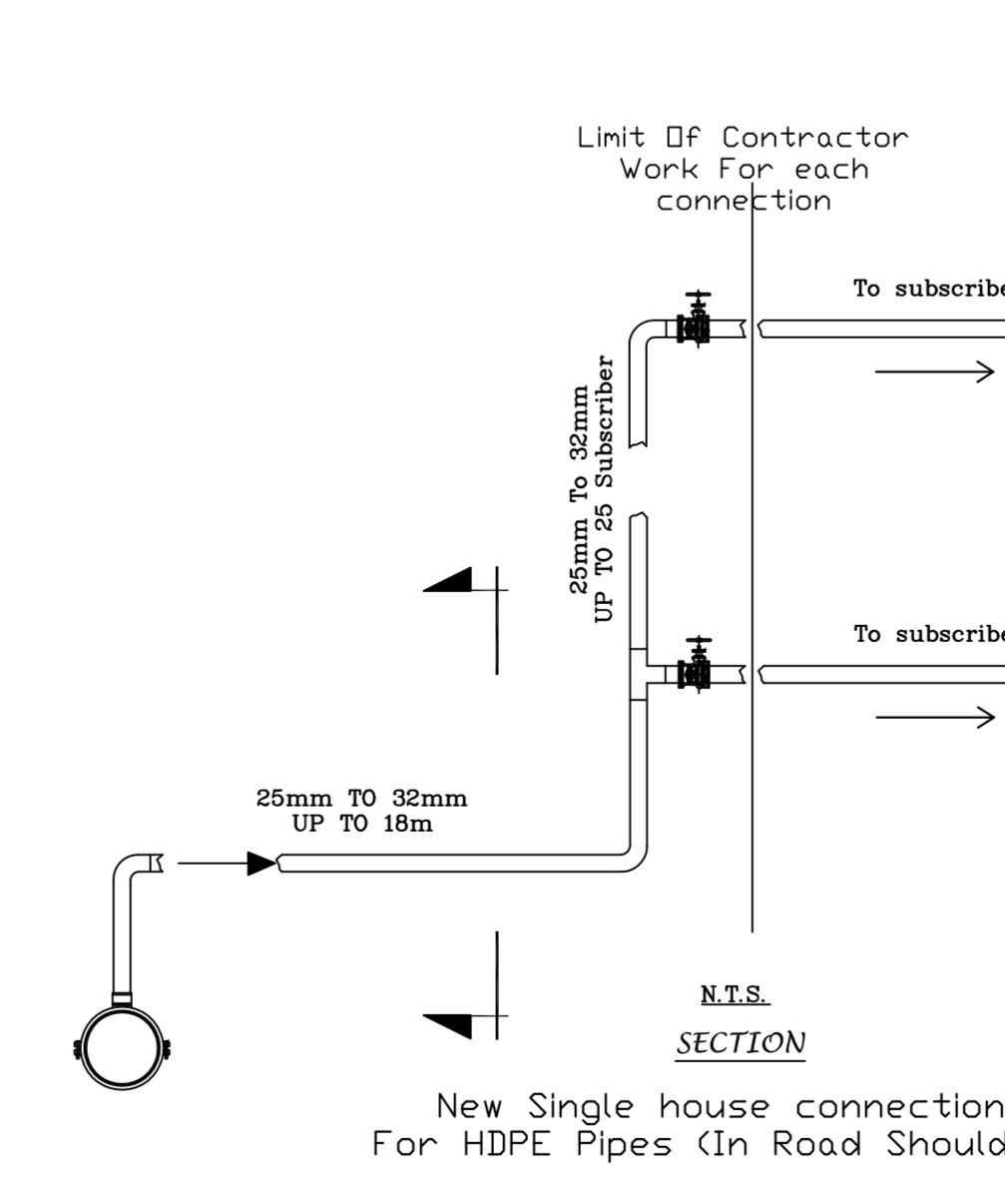

TYPE N2-E1

Lebanese Republic



Ministry of Energy and Water
Directorate of Water & Electrical Resources

WADI JEZZINE WATER PROJECT

PROJECT: Construction of New Potable Water Network in WADI JEZZINE Village-Caza JEZZINE	DATE: February 2017
DWG TITLE: Standard Details	Designed by: D.G.
SCALE: N.T.S	Drawn by: D.G.
	Approved by: N.C.
	Checked by: N.C.

REMARKS:
DRAWING SIZE A0

DWG N°:	Dwg: 2/2
REVISION:	DATE:

